

VEX330H

Air handling units with counter flow heat exchangers

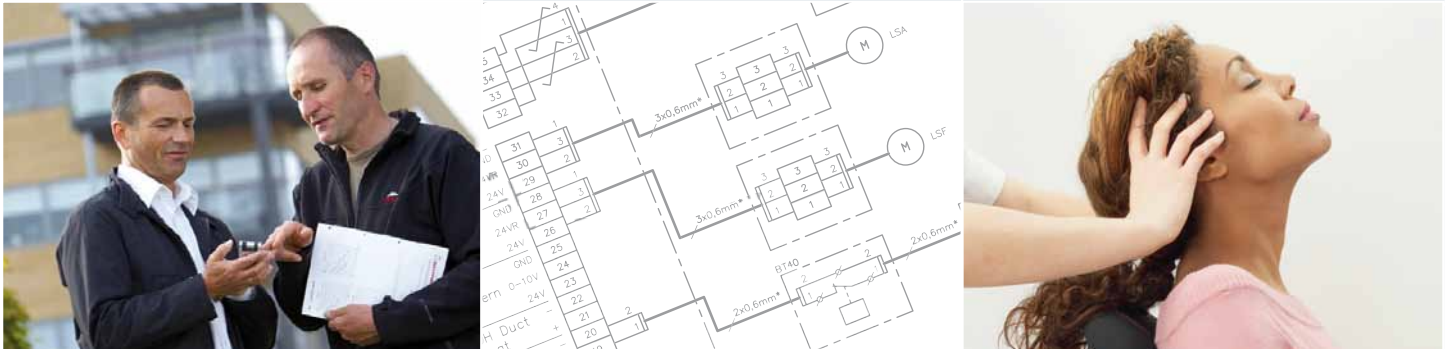

VEX330H: 150-1500 m³/h



EXHAUSTO

FOR A BETTER FLOW



Table of contents

VEX330H (150-1,500 m³/h) 4

- Technical specifications 4
- Capacity curves - compact filters 5
- Temperature efficiency 6
- Sound diagrams 7
- Dimensional sketches 9

EXpert Control System 10

- Control and Operation 10
- Dimensions and positioning 11
- Function overview 12
- Heating and cooling control 13
- Temperature adjustment 14
- Other functions 15
- Innovative ice detection and control system 16

The VEX330H in general 17

- Energy calculations 17
- Cable plans 18
- Simplified diagrams 19

Find more information

Technical submission data can be found on our website under each individual product.

The website also allows users to make technical submission calculations and find prices of the complete system and accessories.



VEX330H range...

Highly-efficient counter flow heat exchangers

VEX330H units are supplied with highly-efficient counter flow heat exchangers, where airstreams are always 100% separated. The bypass de-icing technology allows continuous operation, even with low outdoor air temperatures.

External connection box

The external connection box ensures easy access when connecting and adjusting.

Air flow direction

The air flow directions (and thus spigot positioning) of VEX330H units differ from traditional exchanger units. Drainage from the condensation outlet is optimised and the risk of ice forming in the counter flow heat exchanger is minimised.

Service-friendly

The unit's large apertures ensure easy access for servicing and cleaning. The filters, counter flow heater and motor section are easy to remove for cleaning, servicing and replacing (filters). The door is hinged and removable.

Flexible design and construction

Front panels and back panels can be removed from either left or right versions of VEX units.

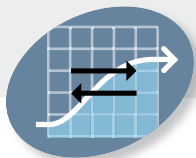
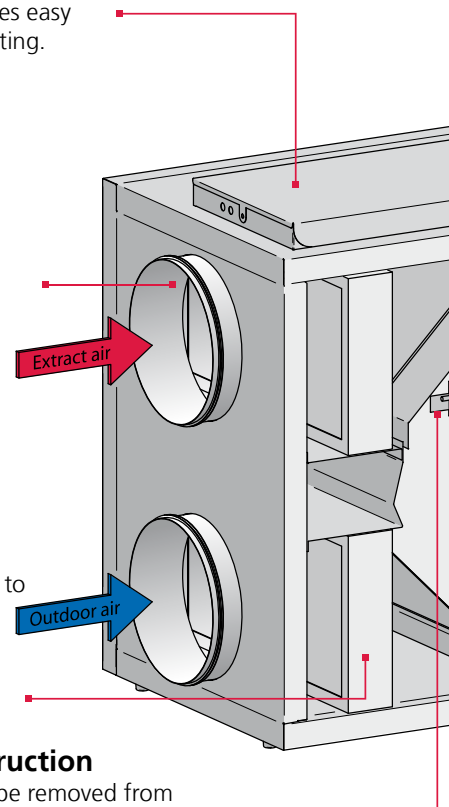

High efficiency

Efficient counter flow heat exchanger delivers optimum efficiency of 85 % or more.



Energy efficient

Low SFP value = lower energy consumption.

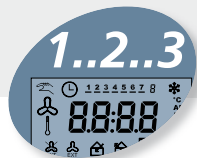

EXpert control

Symbols makes operation simple.

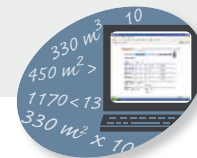

Online calculation

User-friendly website for professionals with news, comprehensive documentation and product calculation programmes.

85% Temperature efficiency or greater ..!

Counter flow heat exchangers create a unit that has an extremely high temperature efficiency and low pressure loss.

- 80-85% efficiency without condensation
- Up to 94% efficiency with condensation

FAST TRACK

Please contact us if you need an extra fast delivery time

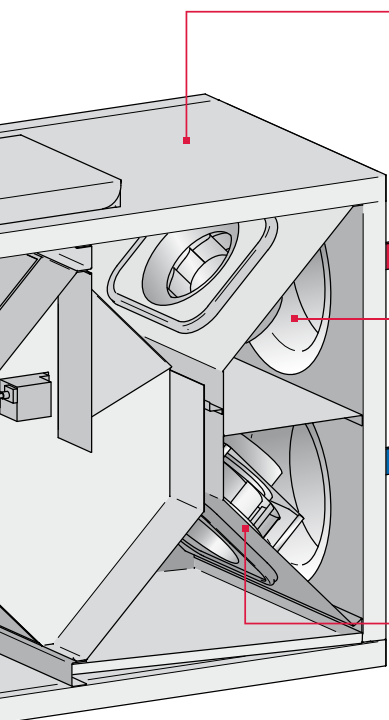

Cabinet
The VEX300H cabinet is made of aluminum-zinc AZ185 C4. The cabinet is insulated with 50 mm mineral wool.

Integrated heating coil
The highly efficient counter flow heat exchanger greatly reduces the need to add heat. But if necessary an integrated comfort heating coil is available with the VEX330H unit. Moreover an integrated pre-heating coil can be fitted so the unit is fully-operational in cold climates.

Fan section with motor
Variable EC motor - low energy consumption, low SFP figures, and low noise level. Steel B-Impeller.

Bypass
Fully-automatic integrated bypass for optimal comfort



Supply air

Exhaust air

EUROVENT certification
The EXHAUSTO air handling units in range VEX300 are all EUROVENT certified. The certificate documents that all technical data provided are third party tested by an individual certification body (EXHAUSTO has been tested and verified by TÜV Nord). This, in terms, means that all data provided by the online calculation tools QuickSelect and EXselect has been verified in tests.

EUROVENT Energy labelling
The EXHAUSTO air handling units type VEX300 are energy labelled according to EUROVENT guidelines for classification of air handling units. The energy class equals the total energy consumption of the unit at given operation parameters.

Find more information on our website



Hygiene
The units are designed and constructed in accordance with German air quality standard VDI 6022.

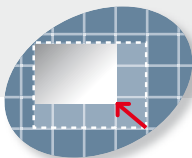

Compact
The unit can be moved through a standard door (900 x 2,000 mm).

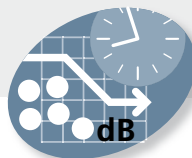

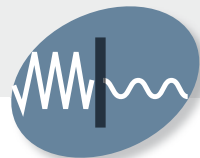
Soundproofed
Save time and money on soundproofing.



Vibration free
Minimum vibration = less noise. The unit can be mounted directly in the ceiling without vibration dampers.

VEX330H - Technical specifications (150-1,500 m³/h)

VEX330H

Unit specifications				
VEX	Motor type	Electrical Supply	Power consumption (kW)	Max. phase current (A)
Without heating	1	1 x 230 V + N + PE ~ 50 Hz	0.6	2.7
	2	1 x 230 V + N + PE ~ 50 Hz	1.5	6.5
With pre-heating (PHCE)	1	1 x 230 V + N + PE ~ 50 Hz	2.1	9.2
	2	1 x 230 V + N + PE ~ 50 Hz	3.0	13.0
	2	3 x 400 V + N + PE ~ 50 Hz	3.0	6.5
With comfort heating (CHCE)	1	1 x 230 V + N + PE ~ 50 Hz	1.4	5.9
	2	1 x 230 V + N + PE ~ 50 Hz	2.2	9.7
With pre-heating and comfort heating (PHCE/CHCE)	1	1 x 230 V + N + PE ~ 50 Hz	2.9	12.5
	2	3 x 400 V + N + PE ~ 50 Hz	3.7	9.8
Principal dimensions, unit excl. spigots and cable duct - for details, see dimensional sketches		Height = 970 mm (plus 62 mm for control equip.) Length = 1,200 mm Depth = 735 mm		
Integrated connection box for control components		Height = 62 mm (see dimensional sketches)		
Cabinet material		Aluminium-zinc AZ185, corrosion class C4		
Insulation		50 mm mineral wool		
Connecting to duct system:		ø315 mm		
Service door (removable)		Two removable panels, one on each side of the unit. Only one side can be opened at a time.		
Filters (outdoor air and exhaust air)	Compact filters Compact filters	qty. 1 F5 - 2.5 m ² , 340 x 630 x 96 mm qty. 1 F7VDI - 7.7 m ² , 340 x 630 x 96 mm		
Weight: fully-operational unit		135 kg (without removable panels = 115 kg)		
Counter flow heat exchanger		Highly-efficient counter flow heat exchanger with aluminium panels		
Median temperature (air)		-20 °C to +40 °C		
Ambient temperature (operating):		-20 °C to +40 °C		
Fan specifications				
Motor and fan type		Variable EC motor (low energy) Steel fan impeller with backwards curved vanes.		
Accessories				
VEX for outside installation		The unit has a special cover and jointing		
Mounting base		Adjustable height 105-135 mm incl. feet		
Filter monitor		qty. 2 - monitors the degree of soiling of the filters		
Pre-heating coils incl. power unit (mounted in outdoor air spigots)		1500 W - maintains operation even in icy conditions		
Comfort heating coils incl. power unit (mounted in supply air spigots)		750 W - for warmer supply air		
Damper	Exhaust damper (LSA) Outdoor air damper (LSF)	24 V damper 24 V damper		

VEX330H - Capacity curves

VEX330H - motor type 1

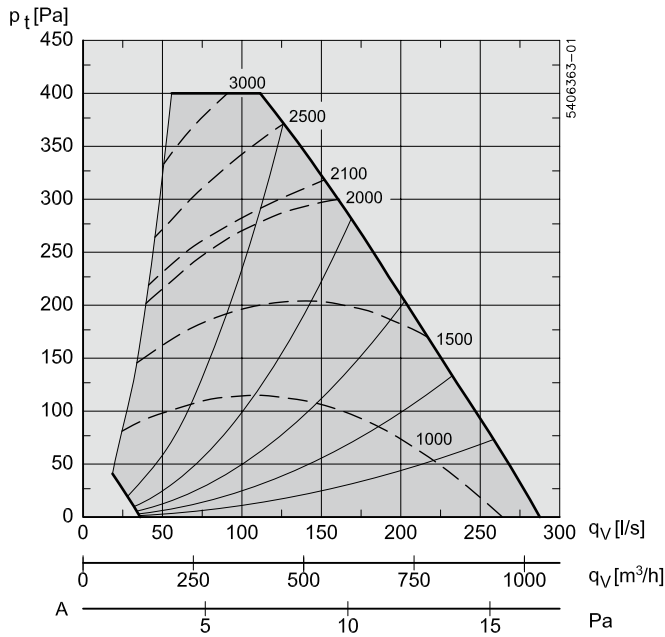

- Capacity curve with F5 filters
- - SFP-curve [J/m³]
- Operation curves
- A = Pressure supplement with F7VDI filter

Total energy consumption is divided equally between the exhaust air fan and the supply air fan.

VEX330H - motor type 2

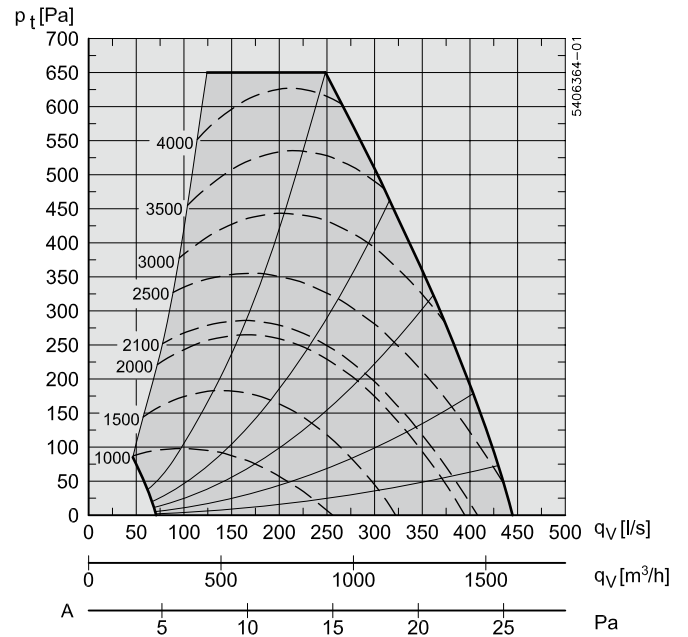

Capacity calculations are based on conditions given on our website.

To calculate capacity data, use our product calculation software on our website

Power consumption for VEX
 $P_i [W] = SFP [J/m^3] \times q_v [m^3/s]$



VEX330H - Temperature efficiency

VEX330H

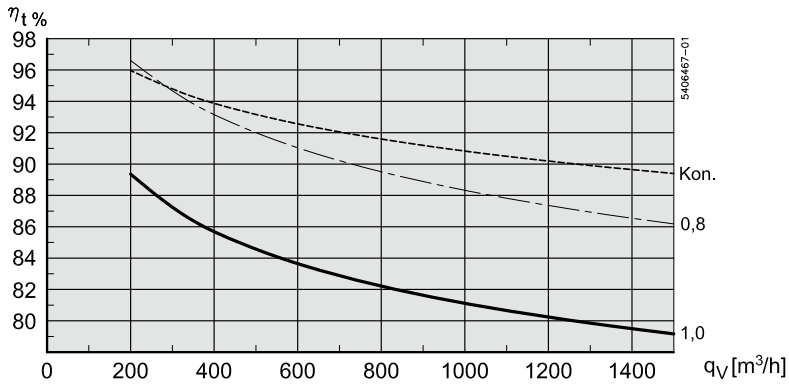

- Efficiency with condensation
Extract air = 20 °C/55% RH - Outdoor air = -10 °C/50% RH
Balance between supply air/extract air = 1.0
- - - Efficiency without condensation med imbalance
Extract = 25 °C/30% RH - Outdoor air = 5 °C/50% RH
Balance between supply air/extract air = 0.8
- Efficiency without condensation according to EN308
Extract = 25 °C/30% RH - Outdoor air = 5 °C/50% RH
Balance between supply air/extract air = 1.0

The VEX unit temperature efficiency is shown at different volume flow ratios, calculated as:

$$\frac{\text{Supply air}}{\text{Extract air}} = 0.8 \text{ and } 1.0$$

$$\eta_t = \frac{t_{2,2} - t_{2,1}}{t_{1,1} - t_{2,1}} = \text{Temperature efficiency}$$

$t_{2,1}$ = Temperature of outdoor air

$t_{2,2}$ = Temperature of supply air

$t_{1,1}$ = Temperature of extract

Sound data - VEX330H-1

VEX330H-1 L_{WA1} - Suction side

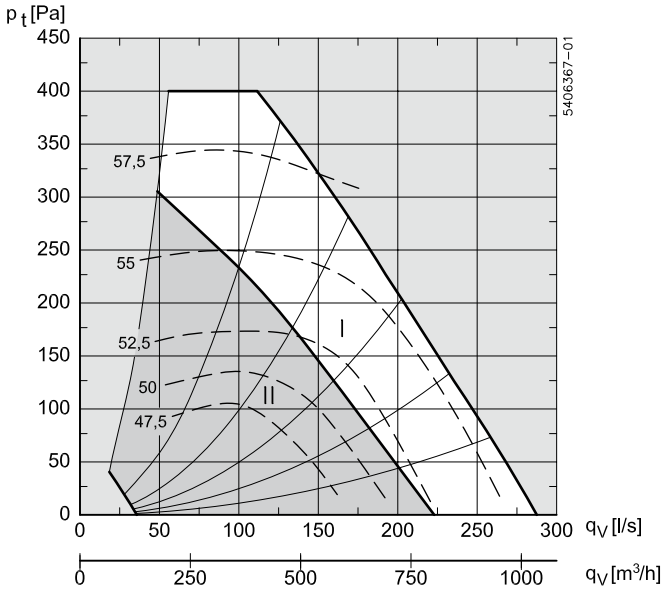

VEX330H-1 L_{WA2} - Pressure side

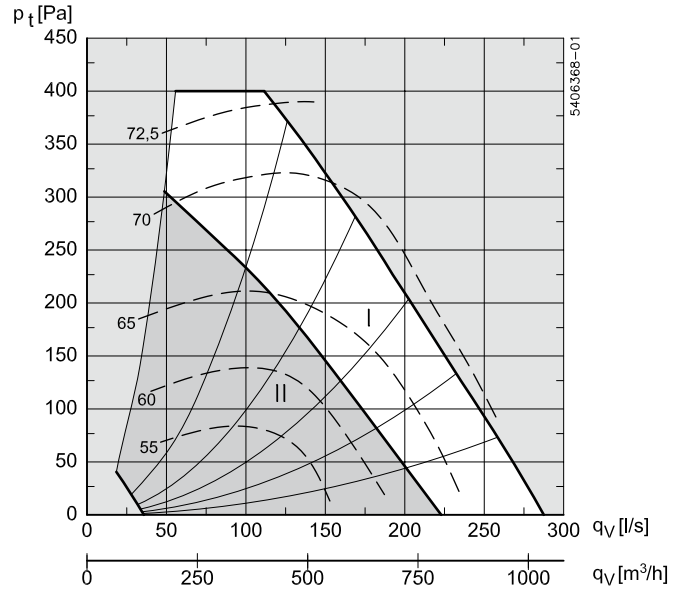

Suction side (outdoor/extract air):

L_{WA1} read from the graph

K_W read from the table

$$L_{W1} = L_{WA1} + K_W$$

Pressure side (supply/exhaust air):

L_{WA2} read from the graph

K_W read from the table

$$L_{W2} = L_{WA2} + K_W$$

		K_W (dB)								K_{pA} dB(A)
Ranges		63	125	250	500	1K	2K	4K	8K	
L_{W1}	I	12	8	5	-1	-11	-18	-27	-33	
	II	14	11	7	-8	-14	-20	-28	-35	
L_{W2}	I	7	7	-1	-2	-6	-9	-15	-23	
	II	12	10	1	-6	-7	-9	-16	-26	
L_{W3}	I	10	15	1	-14	-18	-21	-22	-22	-15
	II	12	15	3	-11	-17	-18	-19	-17	-15

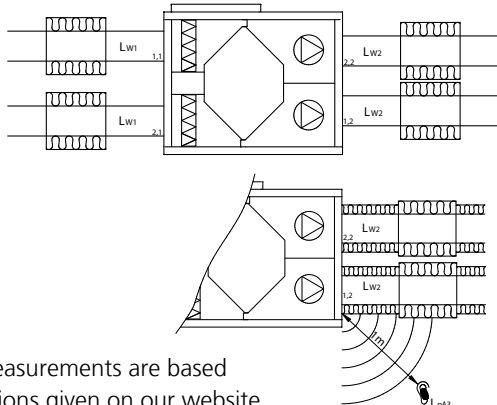

Sound measurements are based on conditions given on our website.

To calculate sound data, use our product calculation software on our website.

VEX330H-1 L_{WA3} - Surroundings

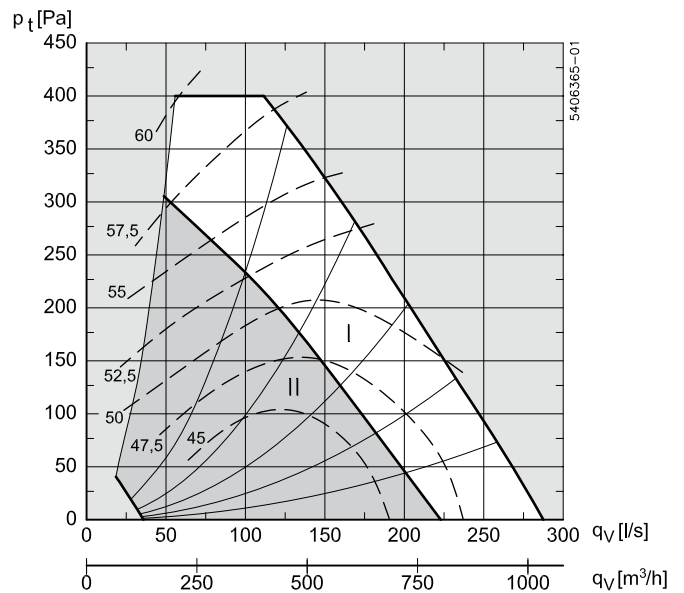

Surroundings:

L_{WA3} read from the graph

K_W read from the table

$$L_{W3} = L_{WA3} + K_W$$

Sound data - VEX330H-2

VEX330H

VEX330H-2 L_{WA1} - Suction side

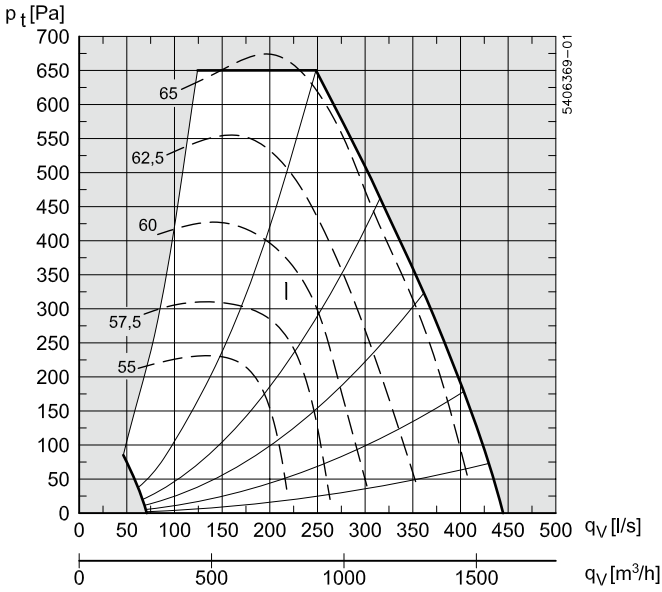

VEX330H-2 L_{WA2} - Pressure side

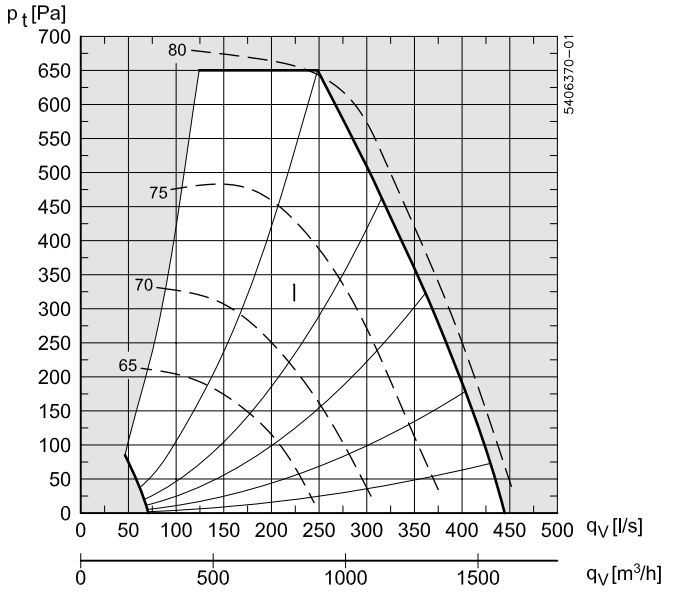

Suction side (outdoor/extract air):

L_{WA1} read from the graph

K_W read from table

$$L_{W1} = L_{WA1} + K_W$$

Pressure side (supply/exhaust air):

L_{WA2} read from graph

K_W read from the table

$$L_{W2} = L_{WA2} + K_W$$

	Ranges	K_W (dB)								K_{PA} dB(A)
		63	125	250	500	1K	2K	4K	8K	
L_{W1}	I	11	8	4	-1	-9	-15	-25	-33	
L_{W2}	I	8	5	-3	-3	-5	-8	-14	-20	
L_{W3}	I	14	14	2	-10	-14	-18	-20	-23	-15

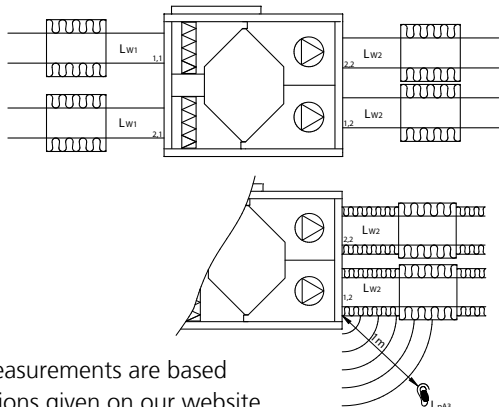

Sound measurements are based on conditions given on our website.

To calculate sound data, use our product calculation software on our website.

VEX330H-2 L_{WA3} - Surroundings

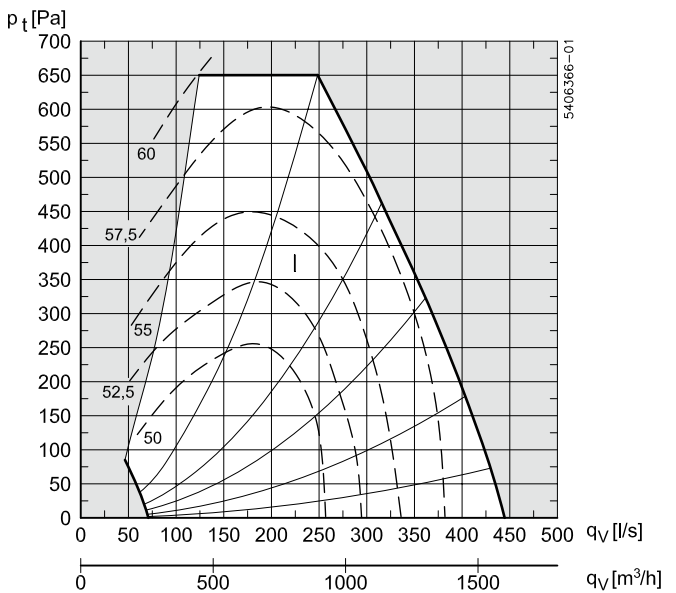

Surroundings:

L_{WA3} read from graph

K_W read from table

$$L_{W3} = L_{WA3} + K_W$$

VEX330H - Dimensional sketches

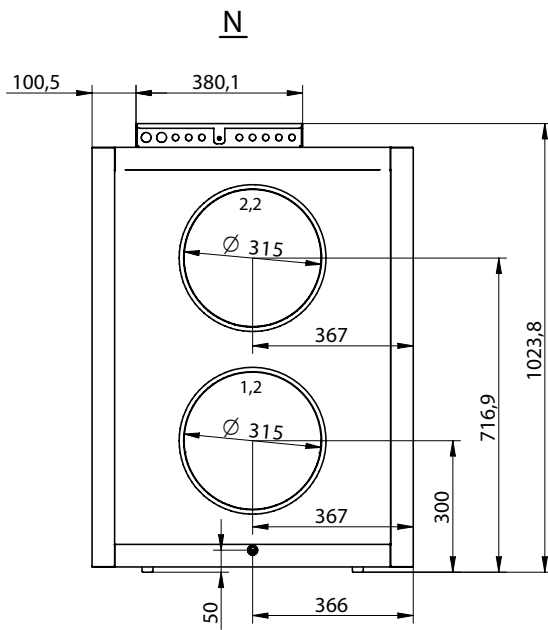
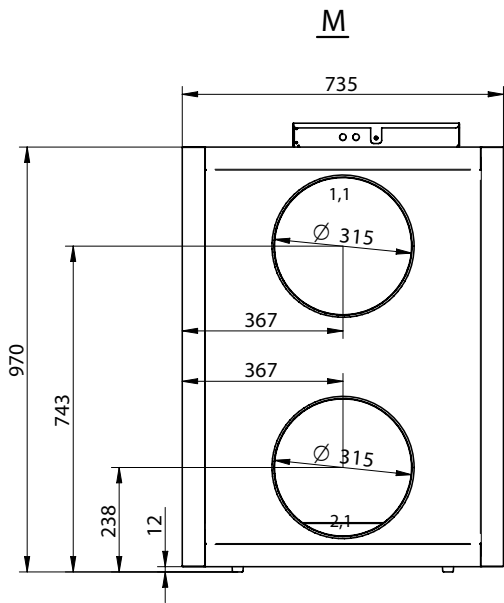
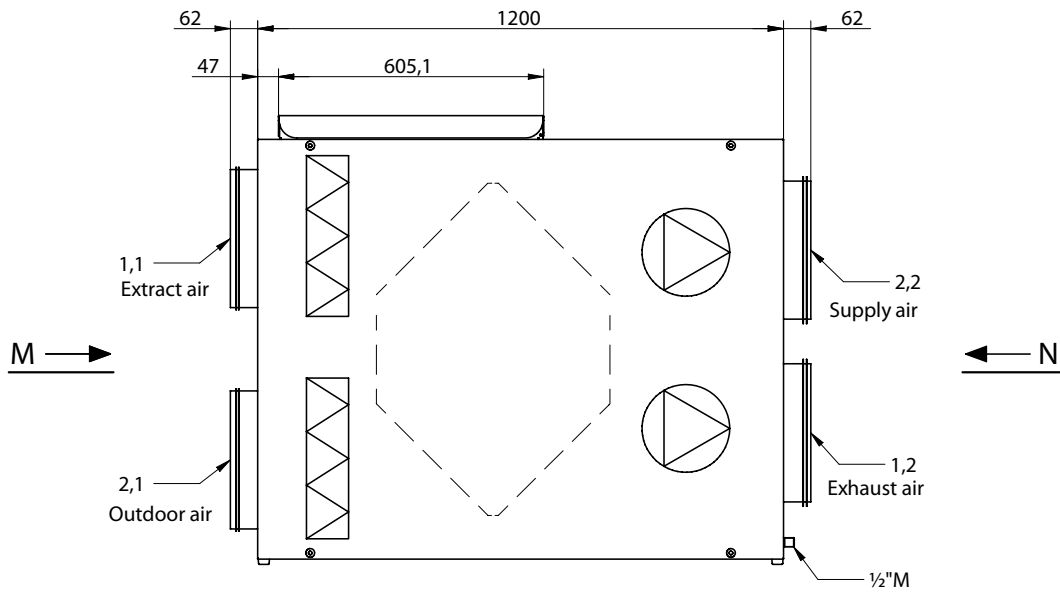

You only need one EXpert to control the VEX330H...

The VEX330H control system is called EXpert - simply the only EXpert you need!



The control panel has a straightforward display, making operation easy. The control panel is used for daily operations, for configuring the unit and for service. The control panel's is password protected (service/operation level).

Alarms

Error and operational alarms are shown on the display. An error will also generate a sound alarm.

Timer control

The EXpert control system has an integrated weekly clock. The operation of the unit can thus be time-set.

Cool recovery

The 330H has automatic cold recovery. This means that on a warm summers day the 'cold' is recovered in the extracted air.

External control

The fan speed can be controlled externally using a 0-10V control signal. This functionality can be linked to other types of sensors, such as CO₂ sensors or other types of external control signals.

Ventilation levels

The VEX330H has nine ventilation levels and an off setting.

Reading the temperature efficiency

The EXpert control panel displays how much energy is being saved. Via built-in temperature sensors in the air stream it is possible to read the actual temperature efficiency during normal operation

Air reduction with low air supply temperature

Supply air temperature is kept in check as much as possible with the set temperature. The automatic bypass control function does this.

If the supply air falls below the set temperature by more than 3 °C, then the airflow is gradually reduced, until a max. imbalance of, e.g. 30% (the max. percentage of imbalance and the desired value can both be set). The air reduction function can be disconnected.

Protection against icing

The EXpert control automatically protects against icing of the counter flow heat exchanger (it is recommended in those countries or areas where the outside temperature is cold that a pre-heating plate is fitted to further protect against icing).

The VEX330H EXpert control panel has two user-defined operator modes:

Operator level	Person	Control possibilities via the EXpert control panel
User mode	Users in the room, office staff, for example.	Setting the airflow and temperature, as well as reading information about the unit's operation.
Service mode	Responsible for the operation of the unit.	Operational factors (clock, temperature limits, etc.) - password access to all readings and settings.

VEX330H control system - Control and Operation

The VEX330H control system has nine different ventilation modes as well as a stop mode. Changing between modes is done manually or automatically, using the EXpert control panel (has a week plan).

The EXpert control panel is used in manual control. Error messages are displayed on the control panel.

Dimensions

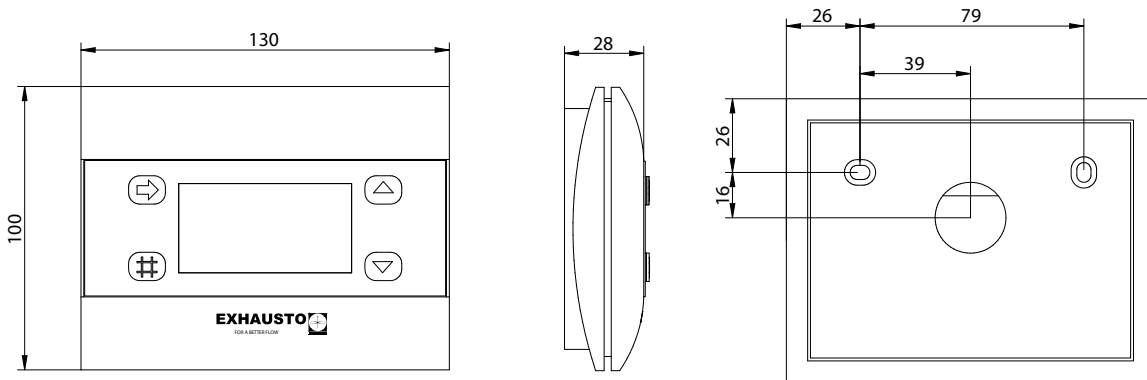

Positioning

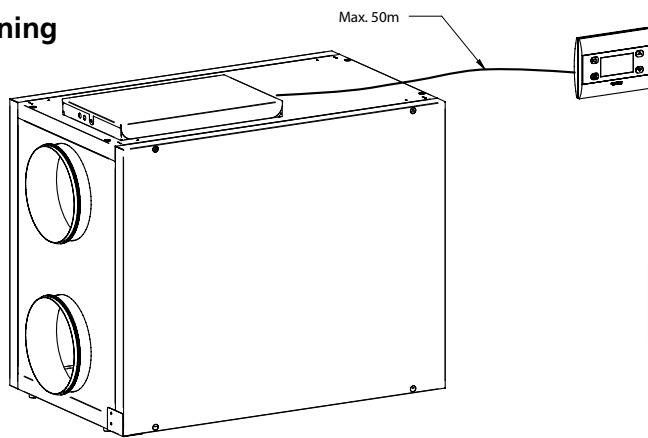

Ingress protection	
EXpert control panel	IP20

Integrated control system

The connection box is an integrated part of the VEX unit. It is fitted onto the top of the VEX for easy accessibility. The filter monitors (accessories) are positioned in the box and the EXpert panel is factory-fitted inside the box on delivery.



VEX330H control system - Functional overview

The table below describes the control system functions.

On the following pages there is a more detailed description of selected functions.

Function / component	Description	● Standard ○ Accessory
Time controlled filter monitor	Automatically reports filter change required (adjustable timer)	●
Filter monitor	Pressure sensors for monitoring the pressure drop across the filters – alarm for a fall more than the value set (due to dirt)	○
Temperature sensor	1) In the extract air spigot for measuring/controlling room temperature 2) In the outdoor air spigot for measuring outside temperature 3) In the supply air spigot for measuring/controlling supply air temperature 4) In the heat exchanger for protection against icing	● ● ● ●
Fire thermostat - 40/50/70°C	The unit reacts to temperatures over 40/50/70°C - manual reset on the thermostat - positioned in the supply/extract air duct can be set so that in the event of fire, the unit: 1) Stops completely or 2) Continues forced supply air and extract air	○
Closing damper - outdoor air	The damper is installed in the outdoor air duct - shuts if the unit stops	○
Closing damper - extract air	The damper is installed in the air extraction duct - shuts if the unit stops	○
Control of supply air temperature	The supply air temperature is regulated to the set temperature	●
EXpert control panel	Control panel for users and technicians	●
Weekly clock	Programmable timer/clock, used to change ventilation levels Day or block programmable	●
Alarm relay	Change relay	●
Cooling control	Control signal to control external cooling unit	●
Duct heating	Control signal for freeing external heat	●
External on/off	External start/stop available via external stop/interrupt signal	●
External control	The ventilation level can be controlled by an external 0-10V signal e.g. CO ₂ and humidity sensor or CTS	●
Pre-heating (PHCE)	With low outside temperatures the outdoor air temperature is raised to protect against icing - overheating protection with manual reset	○
Comfort heating (CHCE)	At low supply air temperatures the CHCE is increased - overheating protection with manual reset	○
Bypass	Automatic bypass for temperature adjustment	●
Air Reduction	Supply air flow is reduced if the temperature is too low - can be disconnected	●
Cool recovery	Cool extract air is used to reduce the supply air temperature if the outdoor air becomes very warm	●

VEX330H control system

- Heating and cooling control



The VEX330H is well-suited to most solutions, with its heating coils and cooling control

Component/function	Use	Description	
Pre-heating coil PHCE (electrical heating)	Can be used to protect the counter flow heat exchanger against icing with low outside temperatures.	The built-in counter flow heat exchanger is very efficient. The unit can extract a lot of energy from the extracted air but condensation occurs and when outside temperatures are low there is a risk this water will freeze, reducing the air circulation of the unit. Pre-warming coils can prevent icing and thus increase reliability by heating the outdoor air before it enters the counter flow heat exchanger. For more details see page 16 (preventing icing). The pre-heating coils can be integrated in the unit. They are optional. They have two thermal fuses and are regulated by a variably adjustable control.	Accessory (must be added to orders if required)
Comfort heating coil CHCE (electrical heating)	Optional choice for maintaining the desired supply air temperature when outside temperatures are low.	An optional comfort heating coil can increase the supply air's temperature. The very high efficiency of the counter flow heat exchanger tends to make the need for extra heating unnecessary. In some cases there may be a need for extra heat for comfort heating. The comfort heating coils are not designed to be the primary heating source. The heating coils can only maintain a given temperature in a room. If chosen, comfort heating coils are integrated into the unit. They have two thermal fuses and are regulated by a variably adjustable control.	Accessory (must be added to orders if required)
External heating	Optional connection of external heat (signal controlled).	If the supply air temperature cannot be maintained, the control system sends a signal to an external heating unit. This only happens after the unit has tried all other options to warm the air.	Not supplied by EXHAUSTO
External cooling	Optional connection of external cooling unit (signal controlled).	The control system can control external cooling units. The VEX330H must be able to communicate with the cooling units, so they are synchronised, otherwise the system will be inefficient and energy will be wasted. If the VEX330H cannot cool the air any further then it will signal the external cooling unit to begin cooling.	Not supplied by EXHAUSTO
Bypass	Airflow passes through or bypasses the counter flow heat exchanger.	VEX330H units have built-in automatic and self-adjusting bypasses. The bypass is variably adjustable.	Standard - incl. in delivery

VEX330H control system

- Temperature adjustment



Regulating the supply air

The EXpert control system controls the supply air temperature. It regulates the temperature to the temperature level set in the control panel.

The system is designed to react slowly (as temperature changes slowly over time) to avoid over shooting. The rate of regulation is adjustable if desired.

The VEX330H is not designed to warm up rooms but will produce the pre-selected supply air temperature.

Many different parameters influence the temperature of a room. These parameters greatly affect the unit's operation and its mode of operation.

Factors such as: Outside temperatures, sources of heat and cold in the room, the number of people in the room, the desired airflow balance, etc.

Component/function	Use	Description	
Heat recovery	An efficient counter flow heat exchanger transmits heat from the extract air into the colder outdoor air.	Counter flow heat exchangers guide the air between parallel aluminium plates, ensuring the highly efficient transfer of heat while keeping the two air streams separated.	Standard - incl. in delivery
Cool recovery	If the air in a room is colder than the outdoor air, the room air will cool the air supply to reduce the air supply temperature.	The VEX330H has automatic cold recovery. This means that on a warm summers day the 'cold' is recovered in the extracted air. This function is especially useful, if some kind of cooling unit is installed in the room.	Standard - incl. in delivery
Air Reduction	When the air supply temperature cannot be maintained, the air supply is gradually reduced. The maximum reduction can be set. The function can be disconnected.	Air Reduction is a function, which can be used when an post-heating coil installation is not desired, or where the heating effect is not sufficient. The supply air flow is reduced as a function of supply air temperature, to maintain the supply air temperature. The function can be disconnected.	Standard - incl. in delivery

VEX330H: Control System

VEX330H control system - Other functions

Other functions

Apart from heating and cooling and temperature regulating, the VEX330H has a series of other functions which are described here.

Component/function	Use	Description	
Filter monitor	Monitoring the soiling of the filters.	The VEX330H is supplied without filter monitoring as standard. But is supplied with a filter timer, which indicates when a filter should be changed after a given operational period. Filter monitoring can be built into the unit. These are located in the connection box and can easily be set during operation. The EXpert control panel indicates the need to change a filter.	Accessories (must be added to orders if required)
External start/stop	The unit can be switched on/off via an external signal.	The VEX330H can be started or stopped via an external stop/interrupt signal. For example the unit can be controlled by another room control system.	There are terminals on the PCB of the controller
External control	External control of airflow function.	The fan speed can be controlled by a 0-10V control signal. This functionality can be linked to other types of sensors (RH or CO ₂) or from an external control system. If this function is selected, then manual control is not possible.	There are terminals on the PCB of the controller
Fire thermostat	Ensures the VEX330H functions correctly in the case of a fire in the ventilated room.	The VEX330H can be fitted with fire thermostats. The unit can be controlled to shut down or operate at full speed if a fire thermostat is activated.	Not supplied by EXHAUSTO
Run on with heating coil	Ensures the correct cooling of heating coils.	Units with electrical heating coils have built-in run on, so that the fans run on for three minutes after the unit has been stopped. After three minutes the heating coils are switched-off.	Function incorporated in the controller

VEX330H - Innovative ice detection & control



Protection against icing with EXpert control system

Highly efficient counter flow heat exchangers can be prone to icing. This is because extracted air from a room contains a small amount of moisture. When the energy from this extracted air is used (when the air cools), the moisture condenses to water vapour, which collects in the heat exchanger. The high efficiency means that some areas inside the heat exchanger become very cold, and the water in these areas will freeze and form ice. This can block the air flow. To counteract this a new control principle has been developed, which ensures continuous operation even at very cold temperatures.

A temperature sensor is positioned in the heat exchanger, where the ice starts to form. As the ice starts to form, the sensor becomes enclosed in ice. The sensor detects the sharp fall in temperature because the extract air no longer flows across it. When that happens the de-icing process begins. Measuring this way allows the system to ensure that de-icing only takes place if required, i.e. when there is moisture and cold.

VEX330H units are delivered with integrated control, ensuring the units do not stop or ice up, so that the heat-exchange process continues even in very cold outside

temperatures. If there is a risk of very cold temperatures over longer periods of time, then it is best to choose a VEX330H with pre-heating coils. Pre-heating coils will ensure continuous operation and heat-exchanging even with cold outside temperatures.

The range of operation can be extended even further, by allowing the unit to run with 30 % imbalance. i.e. the unit reduces supply air by up to 30 % in relationship to extract air. This is not desired in some installations and therefore the option is selectable via a dip switch in the connection box.

The de-icing function depends on whether pre-heating is fitted or whether imbalance is acceptable (is set in the connection box).

There are six steps in the icing-control. The temperature levels at which the control switches from one step to the next are very much dependent on air, temperature and the system. The examples below are merely guidelines and must not be used for calculating.

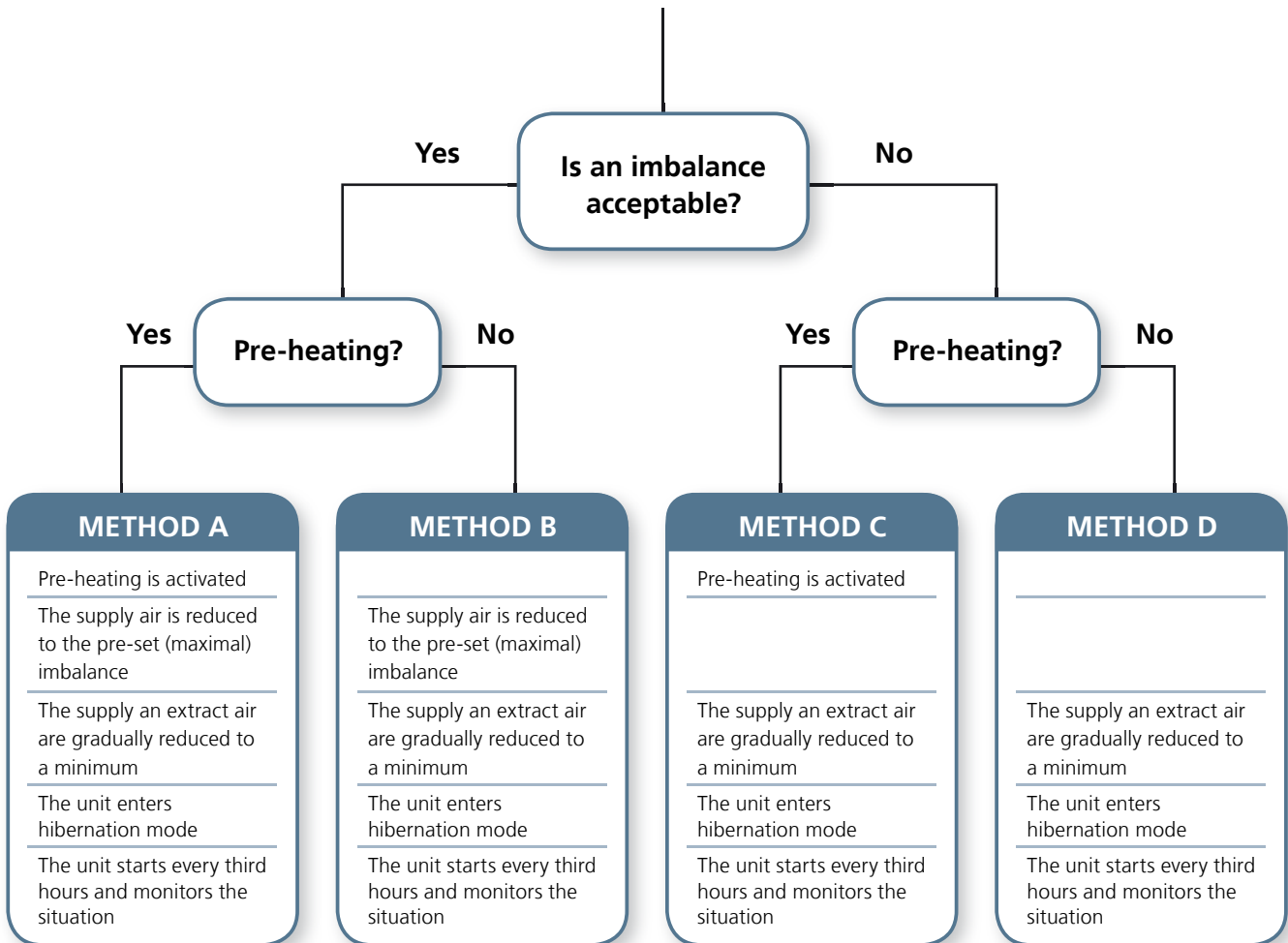

VEX330H: Control System

VEX330H - Energy calculations

Minimal heat loss with VEX330H!

Ventilation and bleed can make up a large part of the energy loss in buildings.

To maintain a good indoor climate it is necessary to have continuous air replacement, so that moisture and odours can be removed from the room. Heat loss related to air replacement is significantly reduced when ventilation units with heat recovery are used. Heat loss is practically zero when the VEX330H is installed.

The advantage of counter flow heat exchangers compared to cross-flow heat exchangers is illustrated in the example below, which shows the variable temperature curve for a whole year (24 hours x 365 days = 8,760 hours).

Conditions:

Extract air temperature: 22 °C
Air supply temperature 20 °C
with equally large airflows

The blue area shows the given share of recovered heat in the heat exchanger, and the red area shows the need for supplemental heat up to 20 °C (desired supply air temperature), in an eventual post-heating coil.

Similar energy calculations can be done in the EXselect product selection programme, where conditions such as operating hours, supply/extract air temperatures can be freely selected.

Cross-flow heat exchanger

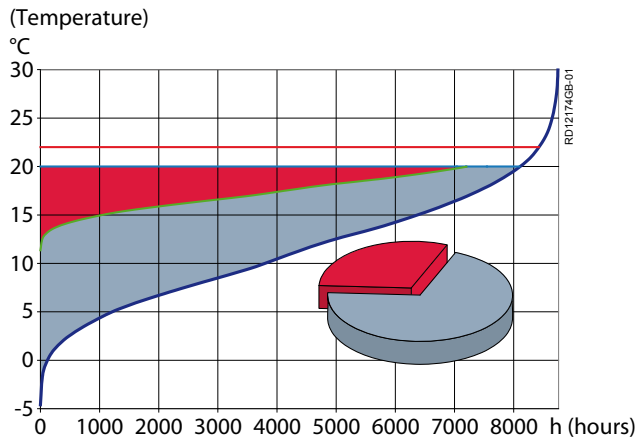

- Outside temperature
- Return air temperature
- Desired supply air temperature
- Temperature after heat exchanger
- Recovered heat
- Heating requirement

VEX330H counter flow heat exchanger

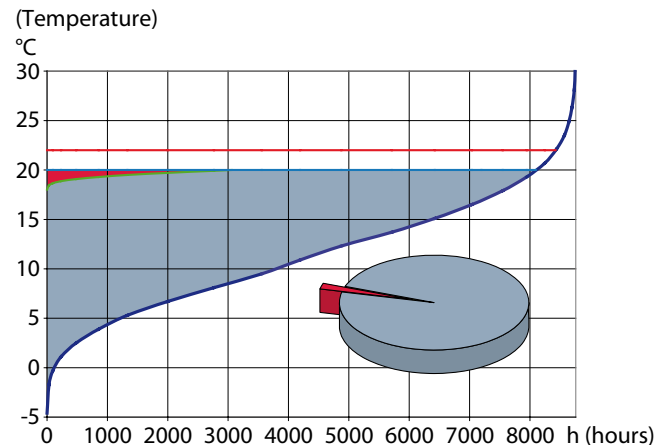

VEX330H - Cable plan

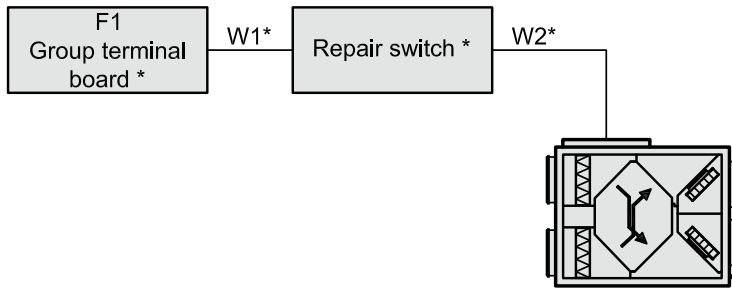

Cable dimensioning

The electrician installing the unit is responsible for ensuring that all sizes used are compatible with current legislation and regulations. The chart below shows dimensioned power values.

Fitting of earth leak circuit breakers

If earth leak circuit breakers are fitted in the installation, they must be of a type that meets the following requirements:

- FI breaker **type A**, as per EN 61008, which breaks the circuit when leakage-current is registered with DC content (pulsating DC)
- Cutout time must be max. 0.3 s.

The current leakage can be up to 300 mA.

Size	PHCE** 1500 W	CHCE** 750 W	Power consumption (max. phase current) (A)	Voltage (V)	Fuses F1 (AgL)*	Cable W1*	Cable W2*
VEX330H-1			2,7	1 x 230 V + N + PE	10	3G1,5	3G1,5
	Yes		9,2	1 x 230 V + N + PE	10	3G1,5	3G1,5
		Yes	5,9	1 x 230 V + N + PE	10	3G1,5	3G1,5
	Yes	Yes	12,5	1 x 230 V + N + PE	16	3G2,5	3G1,5
VEX330H-2			6,5	1 x 230 V + N + PE	10	3G1,5	3G1,5
	Yes		13,0	1 x 230 V + N + PE	16	3G2,5	3G1,5
	Yes		6,5	3 x 400 V + N + PE	10	5G1,5	5G1,5
		Yes	9,7	1 x 230 V + N + PE	13	3G1,5	3G1,5
	Yes	Yes	9,8	3 x 400 V + N + PE	13	5G1,5	5G1,5

* Not supplied by EXHAUSTO ** Heating coils

Cable plan - accessory

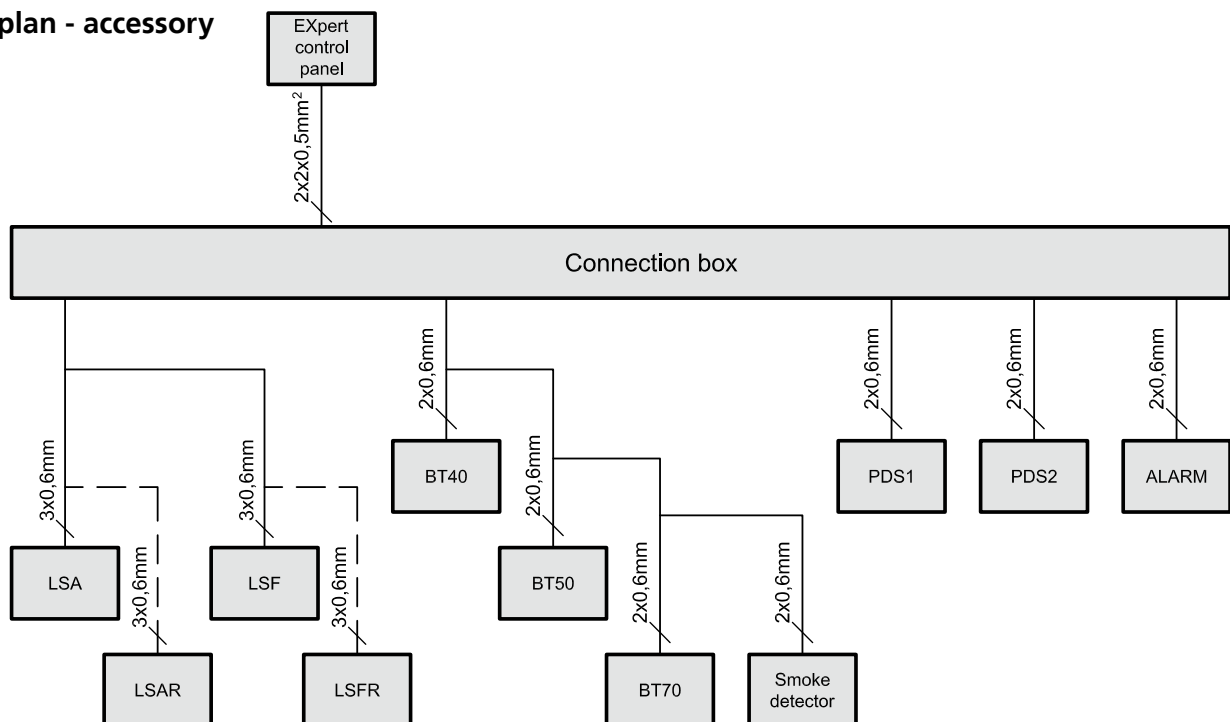

VEX330H - Simplified diagram

The VEX330H is supplied with components fitted in the unit or for fitting in the duct system and in the appropriate room. The layout drawings show the components that can be fitted in a VEX330H air handling unit. The table lists the components for the VEX330H. Accessories must be ordered separately.

Abbreviation	Description	● = Standard ○ = Accessory
BT40/BT50	Fire thermostat 40/50, extract air	○
BT70	Fire thermostat 70, supply air	○
CHCE	Comfort heating	○
LSA	Closing damper, exhaust air	○
LSF	Closing damper, outdoor air	○
M1	Extract/Exhaust air motor	●
M2	Outdoor/Supply air motor	●
M3	By pass motor	●
PHCE	Pre-heating coils	○
PDS1	Filter monitor, extraction	○
PDS2	Filter monitor, outdoor air	○
T_ICE	Temperature sensor for ice in the heat exchanger	●
TE11	Temperature sensor, extract air	●
TE21	Temperature sensor, outdoor air or PHCE	●
TE22	Temperature sensor, supply air	●
TSA70	Overheating electric heating coil (automatic reset)	○
TSA90	Overheating electric heating coil (manual reset)	○

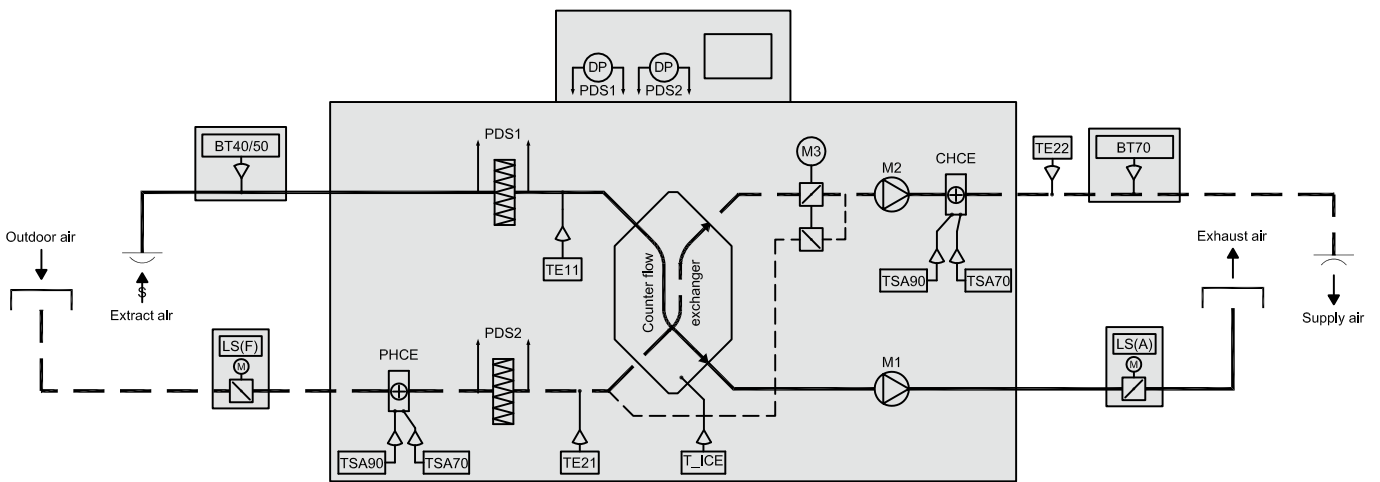

EXHAUSTO - indoor air quality makes a difference



Technologies

EXHAUSTO provides three technologies within heat recovery, cross-flow heat exchangers, rotary heat exchangers and counter flow heat exchangers. The three technology platforms have their own unique advantages and applications.

Our innovation is aimed at energy optimisation in all regards - we develop products that set the standard for future energy requirements.

System solutions

EXHAUSTO consistently develops system solutions that support professional project planning of ventilation for residences, offices and schools. Every single system meets both regulatory requirements and building owners' needs and requirements.

The individual systems are naturally supported by the EXHAUSTO products best suited to each and every installation.

Indoor air quality competences

EXHAUSTO is part of VKR Holding A/S, incorporated in the company's ventilation and indoor climate business area. VKR Holding A/S aims to provide customers with innovative and energy-efficient solutions to ensure an excellent indoor climate in new and existing buildings. To read more visit www.vkr-holding.com At EXHAUSTO, we consistently strive to improve the performance of our products, to enhance not only indoor air quality but also the global climate – benefiting everyone. It's about finding the balance between comfort, energy-efficient solutions and economically-viable operating solutions.